

Heavy Duty Gas Countertop Griddle

Adcraft's heavy duty gas countertop Griddles are designed for use with either natural or LP gas. Constructed of stainless steel front and sides that are fully welded, these units are able to stand the toughest of kitchen environments.



Standard Features

- Stainless steel front bullnose design and splash guards that are fully welded for extra durability
- 30,000 BTU per burner
- One U-shape burner for every 12" griddle width
- Griddle plate is made up of 3/4" thick steel
- 3" wide grease trough for easy cleaning
- 4"-5" adjustable legs
- Separate gas valves for each burner with standing pilot ignition system
- Removable stainless steel drip tray for easy cleaning
- 3/4" rear NPT gas inlet
- ETL Listed and ETL Sanitation

Warranty

Admiral Craft Equipment Corp. (Adcraft) warrants this product to be free of defects in materials and workmanship for period of 1 year from the date of original installation.



Model	Overall Width	Burners	Total BTU	Net Weight (lb)	Gross Weight (lb)
CTG-24	24"	2	60,000	179	212
CTG-36	36"	3	90,000	273	306
CTG-48	48"	4	120,000	353	386



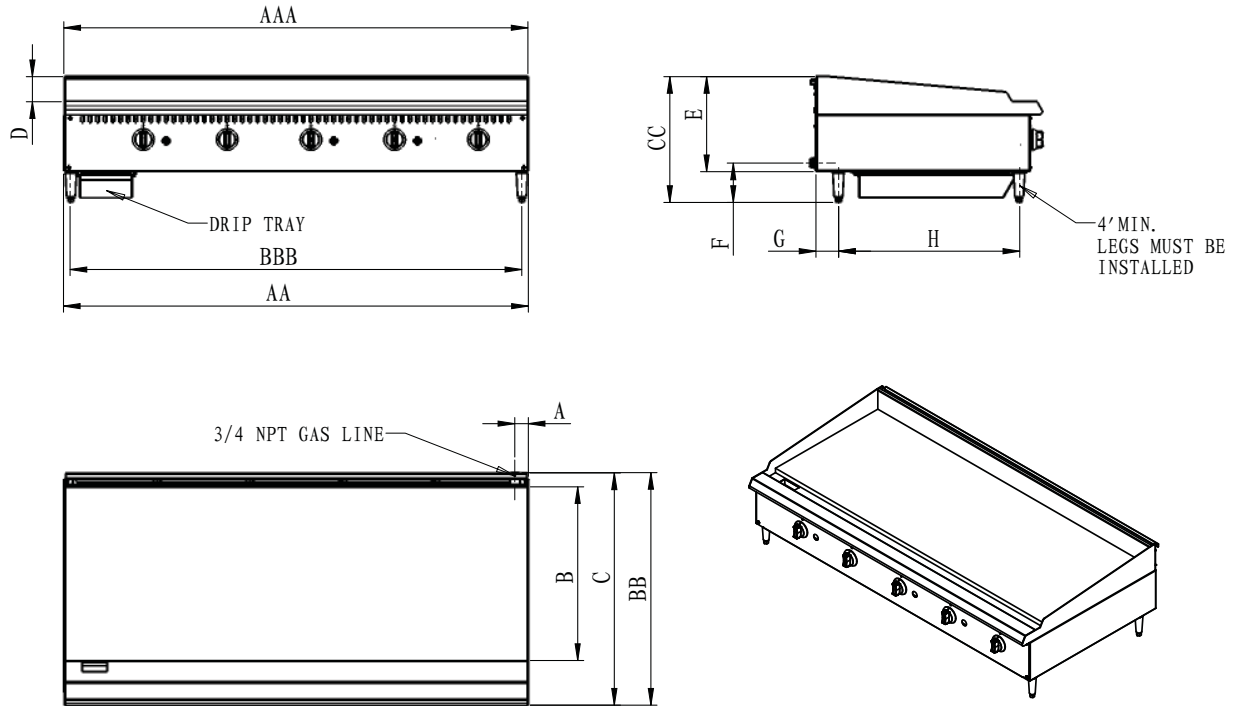

Unit Dimensions (inches)

Model	A	B	C	D	E	F	G	H	AAA	BBB	AA	BB	CC
CTG-24	1.75	22.5	30	3.25	12.25	5	3	23.3	24	22.25	24	30	16.25
CTG-36	1.75	22.5	30	3.25	12.25	5	3	23.3	36	34.25	36	30	16.25
CTG-48	1.75	22.5	30	3.25	12.25	5	3	23.3	48	46.25	48	30	16.25

Drip Tray (inches)

Model	Width	Depth	Height	Drip Tray Qty
CTG-24	7.5	20.5	3	1
CTG-36	7.5	20.5	3	1
CTG-48	7.5	20.5	3	1

Admiral Craft Equipment Corp.
 940 South Oyster Bay Rd.
 Hicksville, NY 11801
 P: 1-800-223-7750
 F: 1-800-447-7751
 www.admiralcraft.com

