

Amana® Commercial

Project #: _____

Item #: _____



Low Volume

Amana® Commercial Microwave RMS Series

Power Output

- 1000 watts of power
- Perfect replacement for inappropriate domestic ovens used in foodservice applications

Available with Touch or Dial Controls

- **Touch controls:**
 - 20 programmable menu items simplifies cooking
 - 5 power levels and 4 cooking stages for cooking flexibility
 - Multiple quantity pad calculates the proper cooking times for multiple portions
- **Dial Controls:**
 - Timer automatically resets to zero if door is opened during heating
 - 6 minute digital timer lights up for “at-a-glance” monitoring
 - Full power only for simple operation

Easy to Use

- See-through door and lighted interior for monitoring without opening the door
- 0.8 cubic foot (23 liter) capacity accommodates a 12” (305mm) platter, prepackaged foods and single servings

Certified Oven for Commercial Applications

- Tested to higher standards for a commercial rating –required by most commercial insurance policies and health inspectors
- Interlock safety switch is tested to 4 times the standard of residential ovens
- Constructed to withstand the foodservice environment, multiple users and variable ambient temperatures
- Compared to a residential oven, this oven is more powerful for faster heating and better quality results
- Engineered for a simple, “self-service” operation

Easy to Maintain

- Stainless steel exterior wrap, door, and oven interior for increased durability
- Sealed-in Borosilicate Glass shelf for easy cleaning

Value Line | Low Volume
This category of microwave oven is ideal for...

Applications

- Convenience Stores
- Coffee shops
- Dessert stations
- Teachers/Staff lounge
- Nurses stations
- Vending

Boost heats and re-therms foods in seconds

- Slice of apple pie re-therms in 20 seconds
- 9 oz. (255g) cup of chili re-therms in 1:45

All ACP, Inc. commercial ovens are supported by our Culinary Center. Do not hesitate to contact us for any questions regarding food preparation, menu development and cooking times: testkitchen@acpsolutions.com



Service

All products are backed by the ACP, Inc.
24/7 ComServ Support Center



Warranty

Warranty Certificate for this product can be found on the ACP, Inc. website at www.acpsolutions.com/warranty



Safety and Sanitation

This ACP, Inc. product meets and exceeds safety and sanitation standards set for commercial microwave ovens by UL, ETL, NSF, CSA, and FDA.



AIA File #:

Specification #:



Amana® Commercial Microwave RMS Series | Low Volume

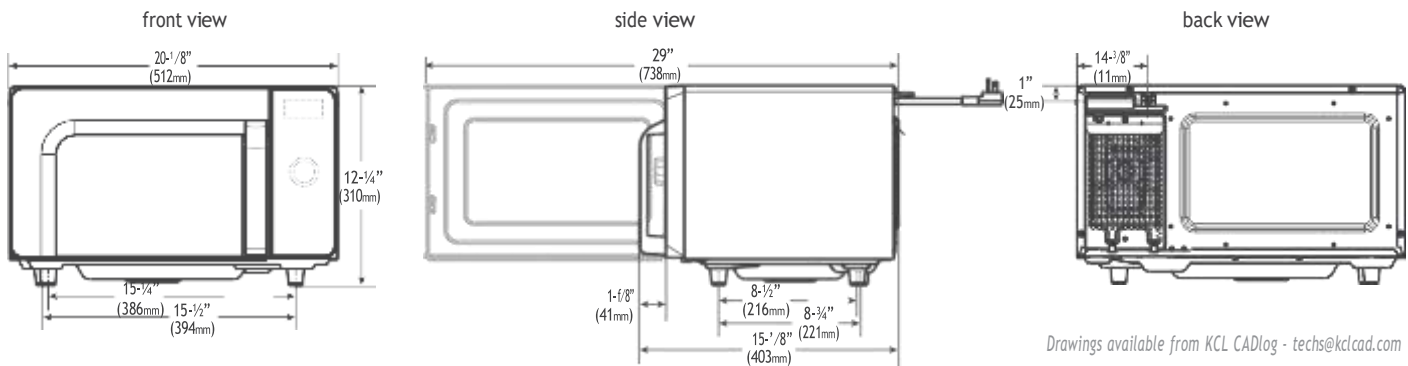

Dimensions

Exterior	H 12 1/4" (310)	W 20 1/8" (512)	D† 15 7/8" (403)
Cavity	H 7 3/4" (197)	W 13" (330)	D 13" (330)
Usable Cavity Space	0.8 cubic ft. (23 liter)		
Door Depth	29" (738), 90° + door open		
Installation Clearances	Top: 7" (177.8)	Sides: 1" (25)	Back: None
Shipping Carton	H 15" (381)	W 23" (584)	D 18" (457)

Weight

Product Weight	Ship weight (approx.)	UPS Shippable
30 lbs. (13.6 kg.)	37 lbs. (16.8 kg.)	Yes

Features

	Touch Models (TS)	Dial Models (DS)
Configuration	Countertop	Countertop
Stackable	No	No
Display	LED	Lighted Dial
Control System	Touchpad	Dial
Programmable Control	Yes, 10 pads	No
Braille	Overlay available	No
Settings Programmable	20	-
Max. Cooking Time	30:00	6:00
Microwave Distribution	Rotating stirrer, bottom	Rotating stirrer, bottom
Power Levels	5	1
Defrost	Yes, 20% power	No
Time Entry Option	Yes	Yes
Multiple Portion Setting	Yes, X2	No
Stage Cooking	4 stages	1 stage
Interior Light	Yes, LED, 42lm	Yes, LED, 42lm
Automatic Voltage Sensor	No	No
Air Filter	No	No
Signal	End of cycle, adjustable	End of cycle
Door Handle	Grab & Go	Grab & Go
Exterior Finish	Stainless steel	Stainless steel
Interior Finish	Stainless steel	Stainless steel

Optional Accessories

- Oven cavity shelf (SE10)
- Non-stick baskets (TB10/S, SB10/S, MB10/S)
- Stainless cart/equipment stands: (CA24, CA30)

Measurements are US Standard. Measurements in () are in millimeters

* IEC 60705 Tested

† Includes handle

Electrical Configuration

Region	Model#/UPC	Control System	Power Consumption	Power Output (microwave)	Power Source	Plug Configuration	Cord Length	Frequency	Magnetron
North America single phase	RMS10TSA 728028470208	Touch	1500 W, 13A	1000 W*	120 V, 60 Hz, 15 A, single phase	NEMA 5-15	5 ft. (1.5m)	2450MHz	1
North America single phase	RMS10DSA 728028470239	Dial	1500 W, 13A	1000 W*	120 V, 60 Hz, 15 A, single phase	NEMA 5-15	5 ft. (1.5m)	2450MHz	1

Specification #:

AIA File #:



225 49th Ave. Dr. SW, Cedar Rapids, IA 52404 U.S.A.
800-233-2366 • 319-368-8120 • Fax: 319-368-8198
www.acpsolutions.com

Part No. 20271101

Updated 06/07/2019

© 2019 ACP, Inc., Cedar Rapids, Iowa 52404

an All Group Company



The Spirit of Excellence

RMS Series

VALUE LINE



RMS10TSA- 1000 Watts, Touch pad controls
RMS10DSA- 1000 Watts, Dial controls

FEATURES AND BENEFITS

- 1000 watts of cooking power
 - Efficient reheating/defrosting reduces food waste
- 0.8 cubic ft. (23 L) oven capacity
 - Accommodates a 12" (305 mm) platter
- Motor driven bottom antenna system
 - Efficient energy distribution for reliable heating results

TOUCH CONTROL MODELS

- 20 programmable menu items
- 4 cooking stages
- 5 power levels

DIAL CONTROL MODELS

- 6:00 light up dial timer
- 100% power only
- Auto reset to zero when cooking is interrupted



Reliable, long lasting Grab 'n Go handle with no moving parts

Available with touch pad or dial controls

IDEAL APPLICATIONS

- Convenience stores
- Dessert stations
- Nurses stations
- Coffee shops
- Teacher's lounge



BOOST HEATS AND RE-THERMS IN SECONDS!

- Slice of apple pie re-therms in 20 seconds
- 9 oz. (255 g) cup of chili re-therms in 1:45